

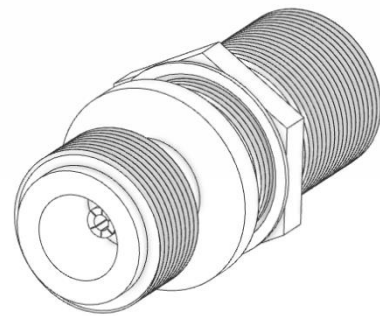

## C5620 N/Female to N/Female Bulkhead Adapter 11 GHZ

Rev 001

<b>Electrical</b>	
Frequency	0-11 GHZ
VSWR	1.30
Impedance	50 Ohms
<b>Mechanical</b>	
N Interface per	MIL-STD-348B
Operating Temperature	-65°C to +165°C
<b>Materials</b>	
Body	Nickel Plated Bras
Contacts	BeCu
Contact Plating	Au 50μ" Min
Dielectric	PTFE
ROHS Compliant	



### Outline

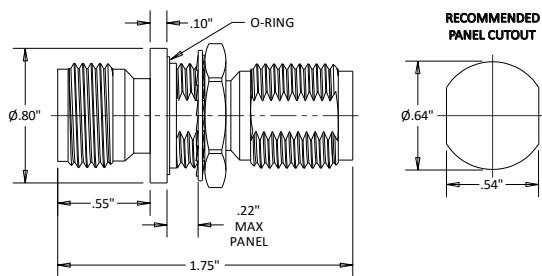

#### Dimensional Tolerances

.X	±.030
.XX	±.010
.XXX	±.005

### Typical Data

