

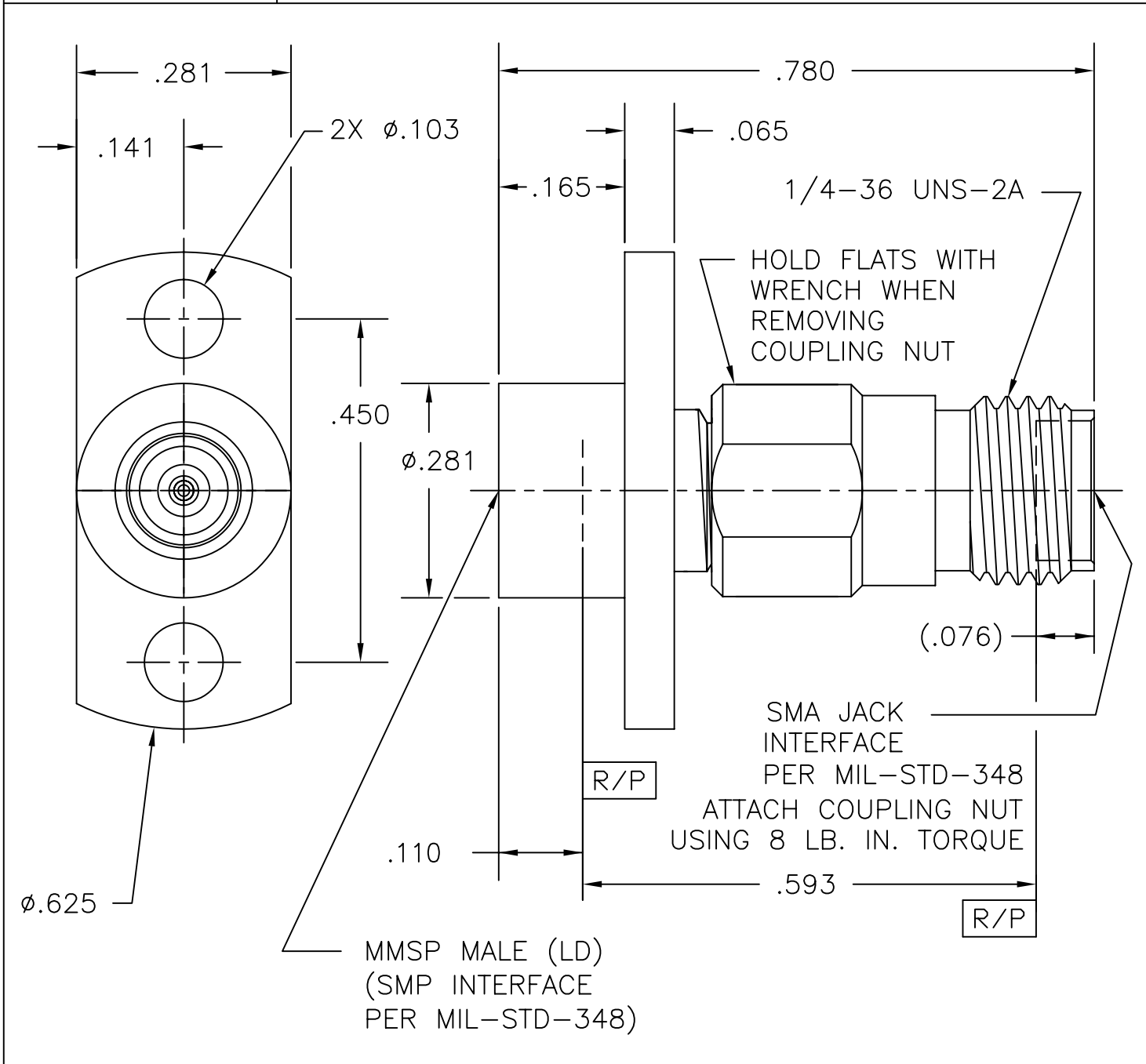

COMPONENT	MATERIAL AND FINISH	
CONTACT	BeCu, ASTM B196, UNS C17300	GOLD PLATE, MIL-G-45204, TYPE 1, GRADE C, CLASS 1
INSULATORS	PTFE, ASTM D1710, TYPE I, GRADE 1, CLASS A	
BODIES	303 CRES, ASTM A582	PASSIVATE, AMS-QQ-P-35

PART NO. MADP-6266

OUTLINE DRAWING



 MICRO-MODE PRODUCTS, INC. <i>The Reliable Connection to the Future</i>	El Cajon, CA 92020 ph 619.449.3844 www.micromode.com	CAGE CODE 15907
	ASSY PROCEDURES: N/A INSERTION/EXTRACTION TOOL: N/A	
SHEET 1 OF 1 OL6266 3-31-99 PC		PART NO. MADP-6266 REVISION E

MMSP(M)LIMITED DETENT FLANGE MOUNT TO SMA (J) ADAPTER